

Instruction

# PAH / PAHT / PAHT G 2-6.3 pumps/ PAH / PAHT / PAHT G 10-12.5 pumps



Table of Contents

1.	Identification .....	2
2.	System design .....	3
2.1	Closed-system design .....	3
2.2	Open-system design .....	4
2.3	General guidelines for calculation of pressure losses .....	5
2.4	General comments on.....	5
3.	Building up the pump unit .....	6
3.1	Mounting.....	6
3.2	Direction of rotation .....	6
3.3	Orientation .....	6
3.4	Protection from too high pressures.....	7
3.5	Connections .....	7
4.	Initial start-up.....	8
5.	Operation.....	8
5.1	Water quality .....	8
5.2	Temperature.....	8
5.3	Pressure .....	8
5.4	Dry running.....	8
5.5	Disconnection .....	8
5.6	Storage.....	8
5.6.1	Water hydraulic systems, water recirculated.....	8
5.6.2	Open-ended systems with water supply from tank.....	9
5.6.3	Open-ended systems with direct water supply.....	9
6.	Service.....	9
7.	Recommended service intervals.....	9
7.1	General information.....	9
7.2	Inspection of pump parts .....	9
7.3	How to inspect the pump .....	9

1. Identification

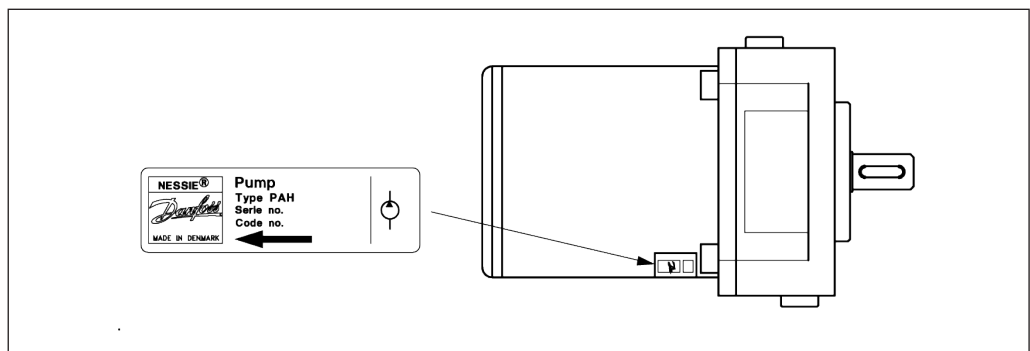

2. System design

2.1 Closed-system design

- A Inlet line:**  
Dimension the inlet line to obtain minimum pressure loss (large flow, minimum pipe length, minimum number of bends/connections, and fittings with small pressure losses).
- B Inlet filter:**  
Install the inlet filter (1) in front of the tank (2). Please consult the Danfoss filter data sheet for guidance on how to select the right filter.
- C Monitoring pressure switch:**  
Install the monitoring pressure switch (3) in front of the filter (1). Set the maximum inlet pressure to 2 barg (29.0 psig). The monitoring pressure switch will stop the pump (5) if inlet pressure is higher than 2 barg (29.0 psig), indicating that the filter element must be changed.
- D Monitoring temperature switch:**  
Install the monitoring temperature switch (4) in the tank. Set the temperature value according to technical data, item 4. The monitoring temperature stops the pump if inlet temperature is higher than the set value.
- E Hoses:**  
Always use flexible hoses (6) to minimize vibrations and noise.

- F Inlet pressure:**  
In order to eliminate the risk of cavitation and other pump damage, pump inlet pressure must be maintained according to specifications described in item 4, technical data.
- G Non-return valve (7):**  
Should be installed after the outlet to prevent pump backspin, which may ruin the pump.
- H Pressure relief valve:**  
As the Danfoss PAHT pump begins to create pressure and flow immediately after start-up regardless of any counter pressure, a pressure relief valve (8) should be installed to prevent system damage.
- I System water filling:**  
To ensure proper filtration of new water (10) supplied to the system, always use the filling valve (9).
- J Minimum level switch:**  
Install the minimum level switch (11) above the outlet of the reservoir. The level switch must stop the pump if the water in the reservoir is below the switch, which indicates that the reservoir is empty.

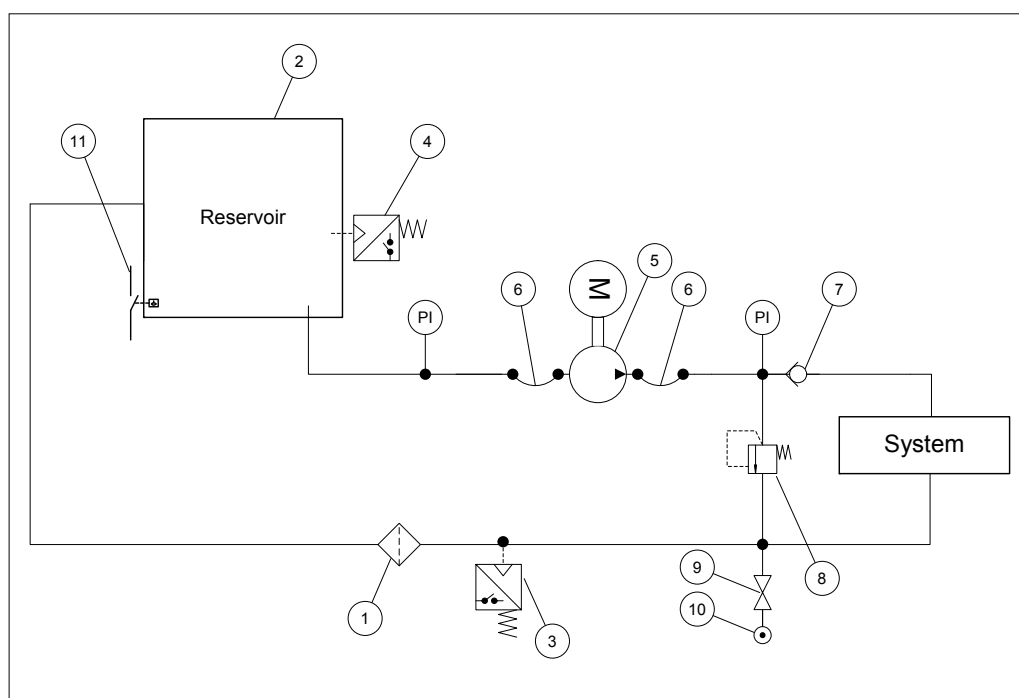

**2.2 Open-system design**

- A Inlet line:**  
Dimension the inlet line to obtain minimum pressure loss (large flow, minimum pipe length, minimum number of bends/connections, and fittings with small pressure losses).
- B Inlet filter:**  
Install the inlet filter (1) in front of the PAHT pump (2). Please consult the Danfoss filter data sheet for guidance on how to select the right filter.
- C Monitoring pressure switch:**  
Install the monitoring pressure switch (3) between the filter and the pump inlet. Set the minimum inlet pressure according to specifications described in item 4, technical data. The monitoring pressure switch stops the pump if inlet pressure is lower than the set minimum pressure.
- D Monitoring temperature switch:**  
Install the monitoring temperature switch (4) between the filter and the pump, on either side of the monitoring pressure switch. Set the temperature value according to technical data, item 4. The monitoring temperature switch stops the pump if inlet temperature is higher than the set value.
- E Hoses:**  
Always use flexible hoses (5) to minimize vibrations and noise.
- F Inlet pressure:**  
In order to eliminate the risk of cavitation and other pump damage, pump inlet pressure must be maintained according to specifications described in item 4, technical data.
- G Non-return valve (6):**  
Should be installed after the outlet to prevent pump backspin, which may ruin the pump.
- H Pressure relief valve:**  
As the Danfoss PAHT pump begins to create pressure and flow immediately after start-up regardless of any counter pressure, a pressure relief valve (7) should be installed to prevent system damage.

**Note: If a non-return valve is mounted in the inlet line, a low-pressure relief valve is also required between the non-return valve and the pump to protect against high-pressure peaks.**

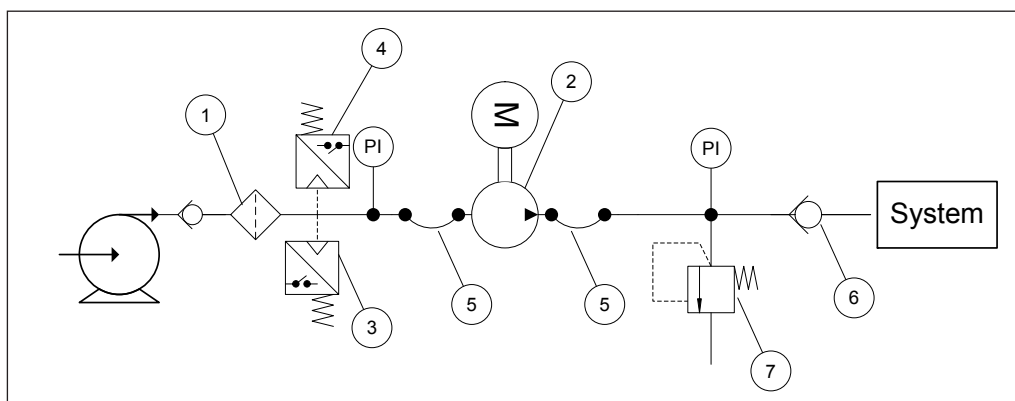

### 2.3 General guidelines for calculation of pressure losses

The suction conditions can be optimized according to below guidelines.

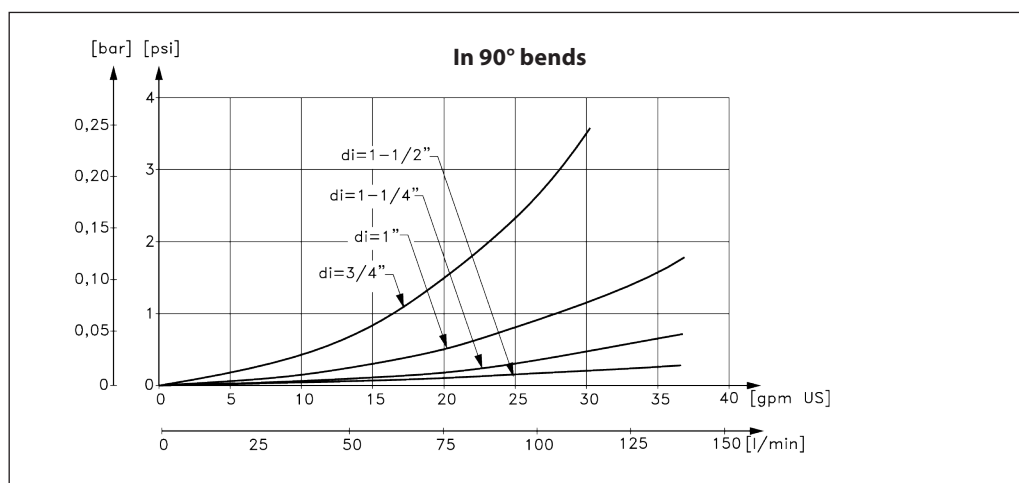
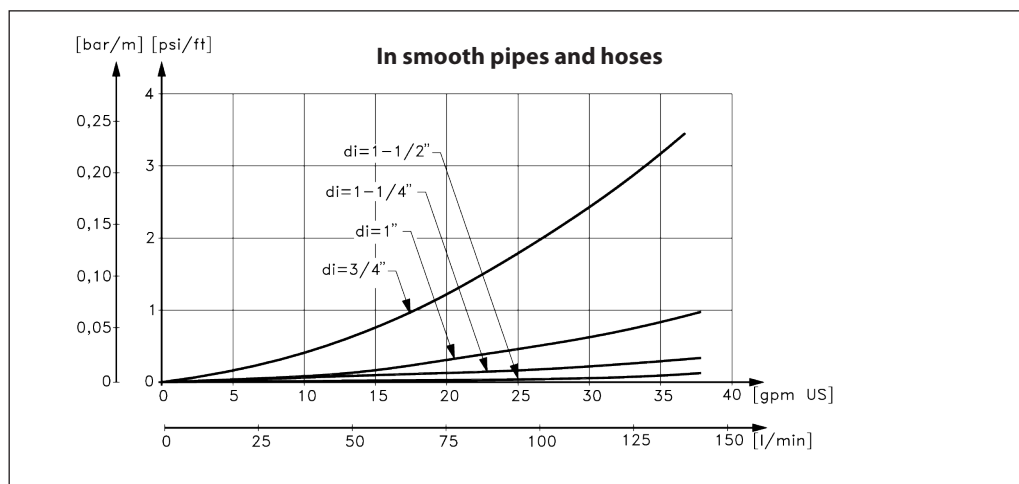

### 2.4 General comments on

#### Filtration

**A good filtration is vital to ensure a long and trouble free life of the pump.**

When selecting a filter or strainer, please note that filter materials should be compatible with water, i.e. should neither corrode or dissolve. Also be aware of the electrochemical series of the applied materials.

- Main filter must have a fineness of 10  $\mu\text{m}$  abs.  $\beta_{10} \geq 5,000$ .
- The pressure loss across the filter should be monitored.
- Please contact the Danfoss Sales Organization for further filter details.

#### Water tank

Must be made of corrosion-proof material such as stainless steel or plastic and must be sealed to prevent entrance of impurities from the environment.

Automatic pressure equalization between tank and surroundings must be ensured.

Inlet from the water supply (the return line) and inlet to the pump should be placed in opposite ends of the tank to calm and deaerate the water, and to ensure optimum opportunity for particles to settle.

Pump suction line should be placed above the tank bottom in order to prevent settled particles from being led into the pump.

We recommend a separation ("wall") to separate the inlet from the outlet end of the tank.

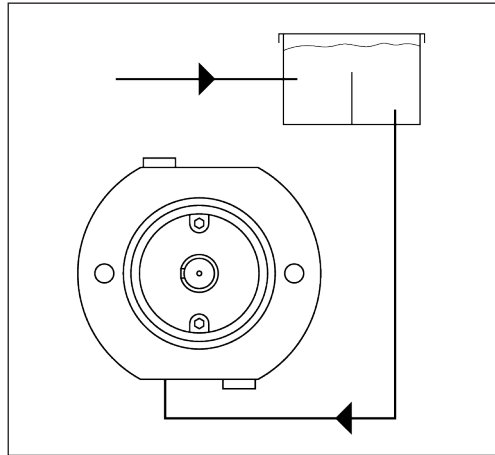

*Monitoring*

It is recommended to continuously monitor the following conditions:

- Water level in the tank
- Filter contamination
- Pressure (inlet- and outlet side of the pump)

**3. Building up the pump unit**

**3.1 Mounting**

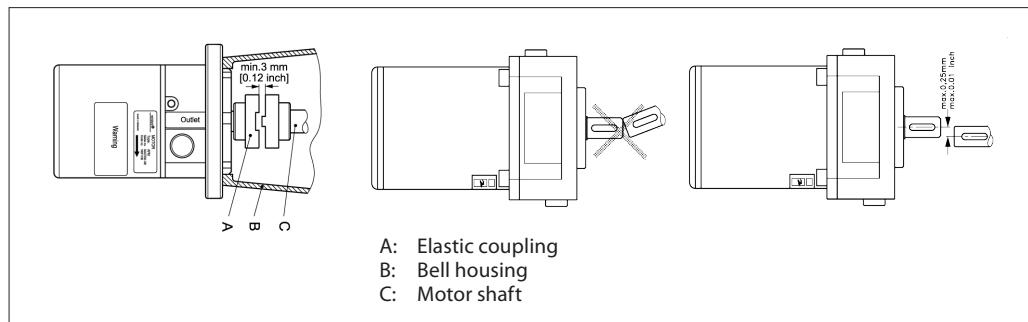

If alternative mounting is desired, please contact the Danfoss Sales Organization.

Choose proper tolerances to ensure an easy mounting of the elastic coupling without use of tools.

Please take care to observe the recommended length tolerances of the chosen coupling, as an axial force on the pump shaft must be avoided.

**3.2 Direction of rotation**

Is indicated by means of an arrow at the label of the pump.

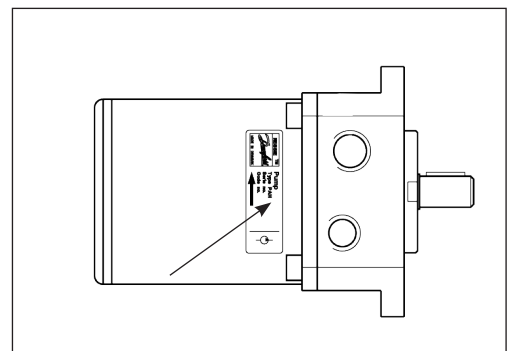

**3.3 Orientation**

The pump can be mounted/orientated in any direction.

**3.4 Protection from too high pressures**

The pump should be protected against too high pressure by means of a pressure relief valve or a bypass/unloading valve placed on the pressure side.

The valve should be placed as close to the pump as possible.

The opening characteristics of the valve must not result in peak pressures higher than 200 bar (2900 psi).

The valve outlet must not be connected directly to the pump suction line. It shall be connected directly to the tank.

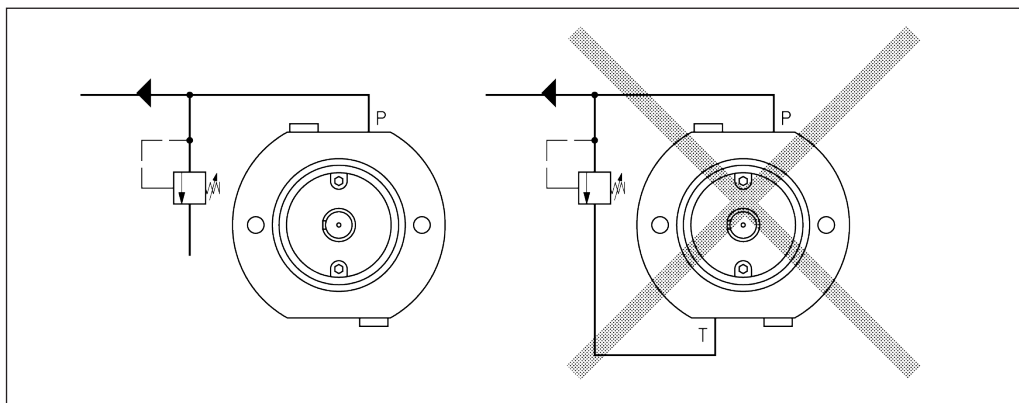

**3.5 Connections**

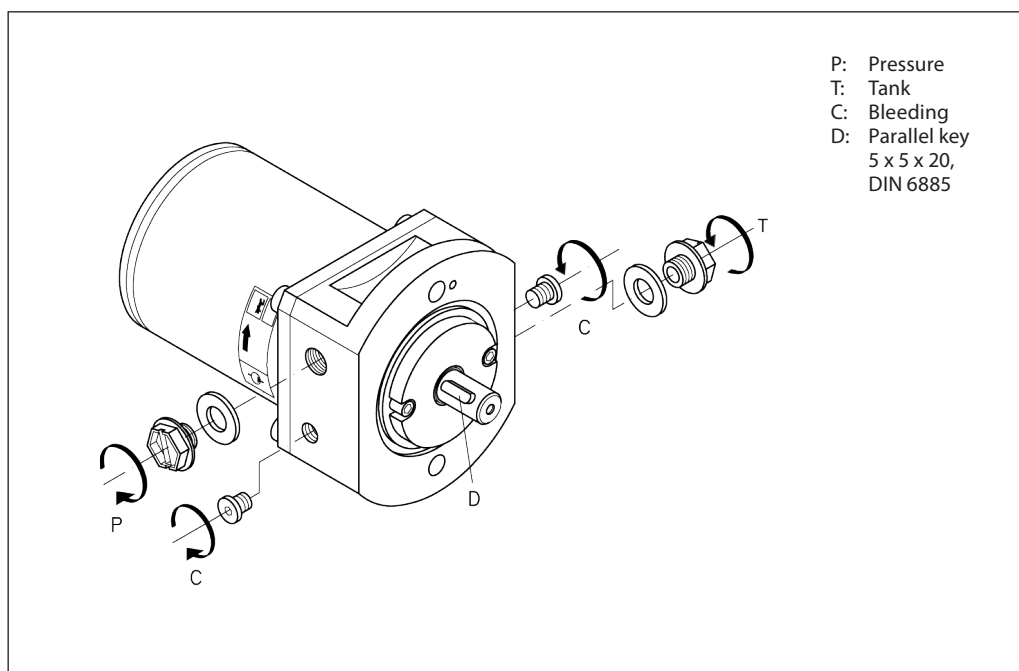

	PAH / PAHT / PAHT G 2-6.3			PAH / PAHT / PAHT G 10-12.5		
	P	T	C	P	T	C
<b>Thread size</b>	G 1/4 x 11	G 1/2 x 15	M6; Allen key 4 mm	G 3/8 x 15	G 3/4 X 17	G 1/4, NV6 14 deep
<b>Max tighten torque</b>	25 Nm	25 Nm	5 Nm	25 Nm	25 Nm	15 Nm

Recommended torque values refer to steel washers containing a rubber sealing element.

**4. Initial start-up**

Before start-up, loosen the top bleeding plug "C". When water appears from the bleeding plug, retighten the plug. With its inlet line connected to the water supply or the tank, the pump is now started with open outlet port.

At the initial start of the system, the pump should be run without pressure for about 5 minutes, thus removing possible impurities from pipes, hoses, etc. However, the system should be flushed before start-up.

**Warning:**  
**Make sure that the direction of rotation of the electric motor corresponds to the direction of rotation of the pump. Otherwise the pump will be damaged if a check valve is placed between pump and tank.**

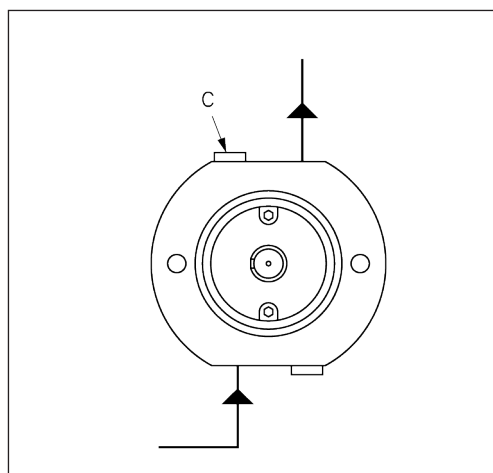

**5. Operation**

**5.1 Water quality**

Water of drinking water quality, confirming to the EEC directive 98/83/EC and without abrasive sediments. Please contact Danfoss sales organization in case of doubt.

**5.2 Temperature**

Fluid temperature	Min. +2° C to max. +50° C
Ambient temperature	Min. 0° C to max. 50° C
Storage temperature	Min. -40° C to max. +70° C

In case of lower operating temperatures, please contact the Danfoss Sales Organization.

**5.3 Pressure**

The inlet pressure must be between min. 0 barg/ 0 psig and max. 4 barg/60 psig. The use of pump outside this range damage the pump.

Max. pressure on the pump's outlet line should be limited at 140 barg (2030 psig) continuously. Short-term pressure peaks (e.g. in connection with closing of a valve) of up to 200 barg (2900 psig) are acceptable.

**NB: The pump unit should include a pressure gauge on the high pressure side.**

**5.4 Dry running**

When running, the pump must always be connected to the water supply in order to avoid damage if it should run dry.

In systems with water tank it is recommended to build in a level gauge in the tank to avoid the risk of running dry.

**5.5 Disconnection**

If the inlet line is disconnected from the water supply, the pump will be emptied of water through the disconnected inlet line.

When starting up again, follow the bleeding procedure described under section 4: Initial start up.

**5.6 Storage**

When preparing the pump for long-term storage or for temperatures below the freezing point, flush the pump with an anti-freeze medium type monopropylene glycol to prevent internal corrosion or frost in the pump. For further information on anti-freeze media, please contact the Danfoss Sales Organization.

**Recommended procedure**

**5.6.1 Water hydraulic systems, water recirculated**

1. Disconnect the power pack from the system.
2. Empty the tank of water. Fill up the tank with anti-freeze medium to a level well above the suction line.
3. Start up the power pack and, for a couple of minutes, in a closed loop system let the anti-freeze medium run back to tank through the pressure relief valve or the bypass valve.
4. Empty the tank of the anti-freeze medium. Empty the pump through the lower bleeding plug.

The pump is now protected against internal corrosion and frost.



**5.6.2 Open-ended systems with water supply from tank.**

1. Empty the tank of water and empty the pump housing through the lower bleeding plug. When the pump is empty, retighten the plug.
2. Through the upper bleeding plug, fill the pump housing with anti-freeze medium. Pour anti-freeze medium into the tank. Connect a hose to the outlet of the pump and lead the other end of the hose back to tank.
3. Quickly start and stop the pump. Make sure that the pump does not run dry.

The pump is now protected against internal corrosion and frost.

**5.6.3 Open-ended systems with direct water supply.**

1. Disconnect the water supply to the pump.
2. Through the lower bleeding plug, empty the pump housing of water and close it again.
3. Connect the pump to a tank of e.g. 25 litre/ 6 gal. of anti-freeze additive. Connect a hose to the inlet port of the pump and via another hose return the flow from the outlet port to the tank with anti-freeze additives.
4. Quickly start and stop the pump. Make sure that the pump does not run dry.

The pump is now protected against internal corrosion and frost.

**6. Service**

The Danfoss PAHT/PAHT G pumps are designed for long periods of service-free operation to provide customers with low maintenance and life cycle costs. Provided that the pumps are installed and operated according to Danfoss specifications, the Danfoss PAHT/PAHT G pumps typically run 8,000 hours between service routines. However, the service schedule for your PAHT/PAHT G pump may vary according to the application and other factors.

The life of a pump may be greatly shortened if Danfoss recommendations concerning system design and operation are not followed.

**In our experience, poor filtration is the number one cause of pump damage.**

Other factors that affect pump performance and lifetime include:

- running the pump at speeds outside specifications
- supplying the pump with water at temperatures higher than recommended
- running the pump at inlet pressures outside specifications
- running the pump at outlet pressures outside the specifications.

**7. Recommended service intervals**

**7.1 General information**

This guideline provides information on the recommended service intervals for the PAHT/PAHT G pumps. The recommendation is based upon good engineering practice and on experience gained from operation even under extreme conditions.

The recommendation is for guidance only.

**7.2 Inspection of pump parts**

Danfoss recommends to inspect the pumps after 8,000 hours. Typical signs of wear are seen on the contact/sliding surfaces in the pumps. If the pumps must run for additional 8,000 hours, the following parts will have to be inspected:

- Pistons
- Retainer plate, ball and bearing
- Valve plate
- Port plate
- Sealings

If there are any wear marks on the parts they need to be replaced.

If service inspection due to the application is complicated, the plant operator can decide to extend the service interval by evaluating the following deviations:

- Sound - does the pump have any unusual sounds?
- Electric motor power consumption and speed compared with measurement made in the past.
- Pressure/flow according to measurements made in the past?

We advise that the above mentioned parameter during the extended service interval is inspected for every 500-2,000 hours beyond the 8,000 hours. The pump must in any case be inspected after maximum 16,000 hours or 2 years.

**7.3 How to inspect the pump**

Service manuals are available on the internet [www.danfoss.high-pressurepumps.com](http://www.danfoss.high-pressurepumps.com)

**Danfoss A/S**  
High Pressure Pumps  
DK-6430 Nordborg  
Denmark

---

Danfoss can accept no responsibility for possible errors in catalogues, brochures and other printed material. Danfoss reserves the right to alter its products without notice. This also applies to products already on order provided that such alterations can be made without subsequential changes being necessary in specifications already agreed. All trademarks in this material are property of the respective companies. Danfoss and the Danfoss logotype are trademarks of Danfoss A/S. All rights reserved.

---